

# CHAPTER-1

## INTRODUCTION

In this model we show that how we can generate a voltage from the busy traffic. Conversion of the mechanical energy into electrical energy is widely used concept. It's a mechanism to generate power by converting the potential energy generated by a vehicle going up on a speed breaker into rotational energy. We have used that simple concept to the project. We connect one mechanical rod with the dynamo and fit this rod on the surface of the road. When any vehicle moves from this roller then due to friction, vehicle Rotate the rod or roller and roller then move the dynamo. When dynamo move then it generates a voltage and this voltage now connects to the bulbs. In actual practice with the help of this voltage we will charge the battery and then we use this voltage to light the small bulb.

If we install this unit to the any small flyover then with the help of this voltage we generate a small voltage, and with the help of this voltage we light the bulb.

The second part of that project is an efficient use of energy by using simple electronics. We always see that road light continuously glow whether vehicle on path or not. We have introduced a concept to avoid a waste of light. We have used two sensors between some distances. When vehicle pass through first sensor it sends the signal to the microcontroller that the vehicle is passing along that particular distance then light will glow for that particular time and when vehicle goes out from the second sensor

**CREATED BY:**  
**ER. GAURAV DWIVEDI**  
**MECHANICAL ENGINEERING**

In that project we have introduced a roller mechanism to convert the mechanical energy into the electrical energy. We have

**C**



connected a roller to the shaft of a dynamo when roller moves it rotates the shaft of the dynamo by that process electricity is generated. In a roller mechanism the maintenance is required of the high level. Material selection is also a important task for the roller type mechanism. The below figure 1.1 shows the basic mechanism of roller type. In that one roller is linked with chain to the shaft of a dynamo, when vehicle moves over a speed breaker then potential energy is converted into a rotational energy which rotates the shaft of a dynamo due to that electricity is generated.

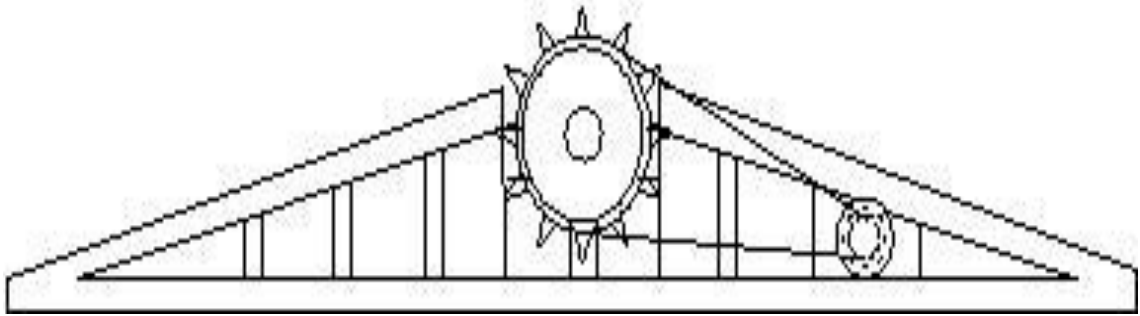

**Fig 1.1** Roller mechanism during electricity generation from speed breaker

By using a crank shaft mechanism we can also generate an electrical power from mechanical power. But the problem of vibration often occurs. Crank shaft are required to be mounted on bearings which creates a balancing problems in that mechanism which leads a problem of mechanical vibration which in turn can damage a bearings.

The third and last mechanism is a rack and pinion mechanism. This mechanism is most efficient mechanism in comparison of the other two. Rack and pinion gives good mounting convenience.

**CREATED BY:**  
**ER. GAURAV DWIVEDI**  
**MECHANICAL ENGINEERING**

Maximum gear losses which occur in that mechanism can lie between three to five percent and efficiency of that mechanism can lie between ninety to ninety five percent. Fig 1.2 shows the basic concept of rack and pinion mechanism.

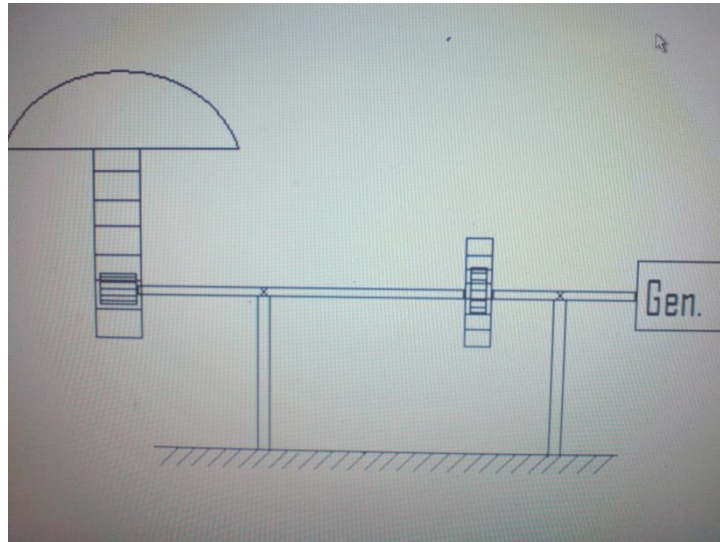

**Fig 1.2**

Rack and pinion mechanism for electricity generation from speed breaker

**CREATED BY:**  
**ER. GAURAV DWIVEDI**  
**MECHANICAL ENGINEERING**

# CHAPTER-2

## OVERVIEW

### 2.1 WORKING PRINCIPLE:

#### 2.1.1 MECHANICAL TO ELECTRICAL ENERGY:

One rod with the dynamo is placed like a speed breaker. Dynamo means a generator that produces direct current with the use of a commutator. The dynamo uses rotating coils of wire and magnetic fields to convert mechanical rotation into a pulsing direct electric current through Faraday's law. A dynamo machine consists of a stationary structure, called the stator, which provides a constant magnetic field, and a set of rotating windings called the armature which turn within that field. Movement of vehicle just rotates the dynamo shaft and electricity is generated. This voltage is to be stored in the chargeable battery.

In the night lights are automatic on with the help of photovoltaic switch logic. But all lights are not on, only half light are on. Other half lights switch on automatically when any vehicle move on the bridge, when there is no vehicle on the bridge then lights are off automatically. We use two infrared sensors' to check the movement of vehicle. When first infra red sensor is on then lights are on and when second sensor is interrupting then lights are off. A Street light, lamppost, street lamp, light standard, or lamp standard is a raised source of light on the edge of a road, which is turned on or lit at a certain time every night. Modern lamps may also have light-sensitive photocells to

**CREATED BY:**  
**ER. GAURAV DWIVEDI**  
**MECHANICAL ENGINEERING**

turn them on at dusk, off at dawn, or activate automatically in dark weather. In older lighting this function would have been performed with the aid of a solar dial. Here we used some electronics for that purpose. It is not uncommon for street lights to be on posts which have wires strung between them, such as on telephone poles or utility poles.

Major advantages of street lighting includes: prevention of accidents and increase in safety. Studies have shown that darkness results in a large number of crashes and fatalities, especially those involving pedestrians; pedestrian fatalities are 3 to 6.75 times more vulnerable in the dark than in daylight. Street lighting has been found to reduce pedestrian crashes by approximately half percent.

## **2.2 CONSTRUCTION & OPERATION:**

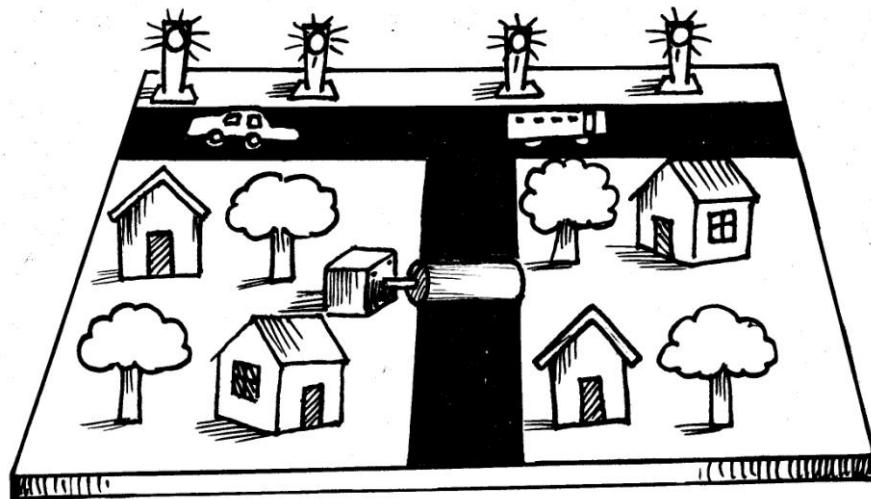

**Fig 2.1**

**CREATED BY:**  
**ER. GAURAV DWIVEDI**  
**MECHANICAL ENGINEERING**

In this model we show that how we generate a voltage from the busy road traffic. In all the city's traffic is very much high and on some road, traffic move like a tortoise. If we employ a speed breaker type generator on the road then we utilize the friction of vehicle into mechanical energy and then this mechanical energy is further converted into electrical energy with the help of the powerful dynamo. So we install a one powerful dynamo on the road.

Output of the dynamo is connected to the L.E.D. in this project. When we move the shaft of the dynamo then dynamo generate a voltage and this voltage is sufficient to drive the L.E.D.

In actual practice we use this dynamo to generate a voltage and after generating a voltage we charge the battery. When battery is fully charged then we use this battery as a storage device. We use this storage device to run the lights of the road. A **rechargeable battery** (also known as a **storage battery**) is a group of one or more electrochemical cells. They are known as **secondary cells** because their electrochemical reactions are electrically reversible. Rechargeable batteries come in many different sizes and use different combinations of chemicals; common types include: lead acid, nickel cadmium (NiCd), nickel metal hydride (NiMH), lithium ion (Li-ion), and lithium ion polymer (Li-ion polymer).

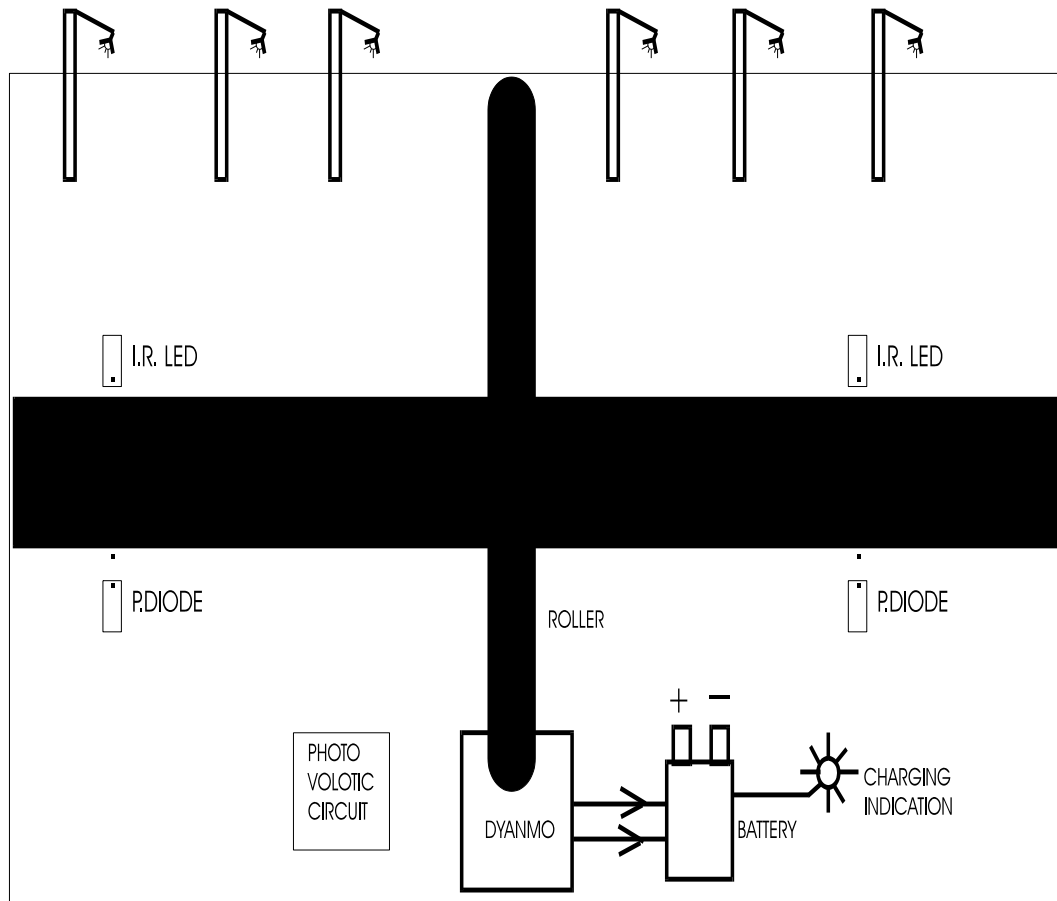

**CREATED BY:**  
**ER. GAURAV DWIVEDI**  
**MECHANICAL ENGINEERING**

**Fig 2.2** Rechargeable battery

**CREATED BY:**  
**ER. GAURAV DWIVEDI**  
**MECHANICAL ENGINEERING**



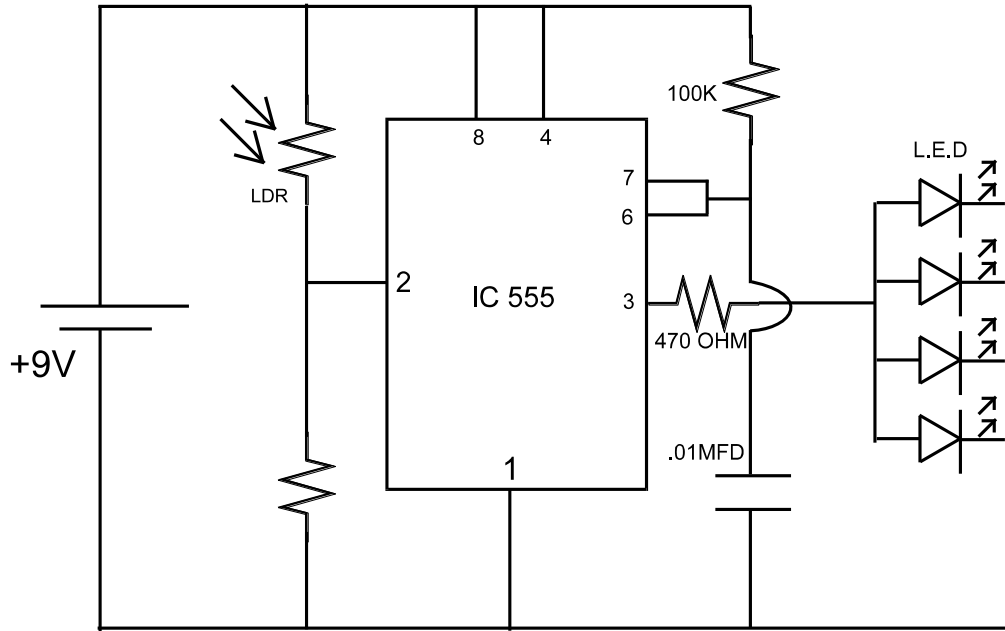

**CREATED BY:-**

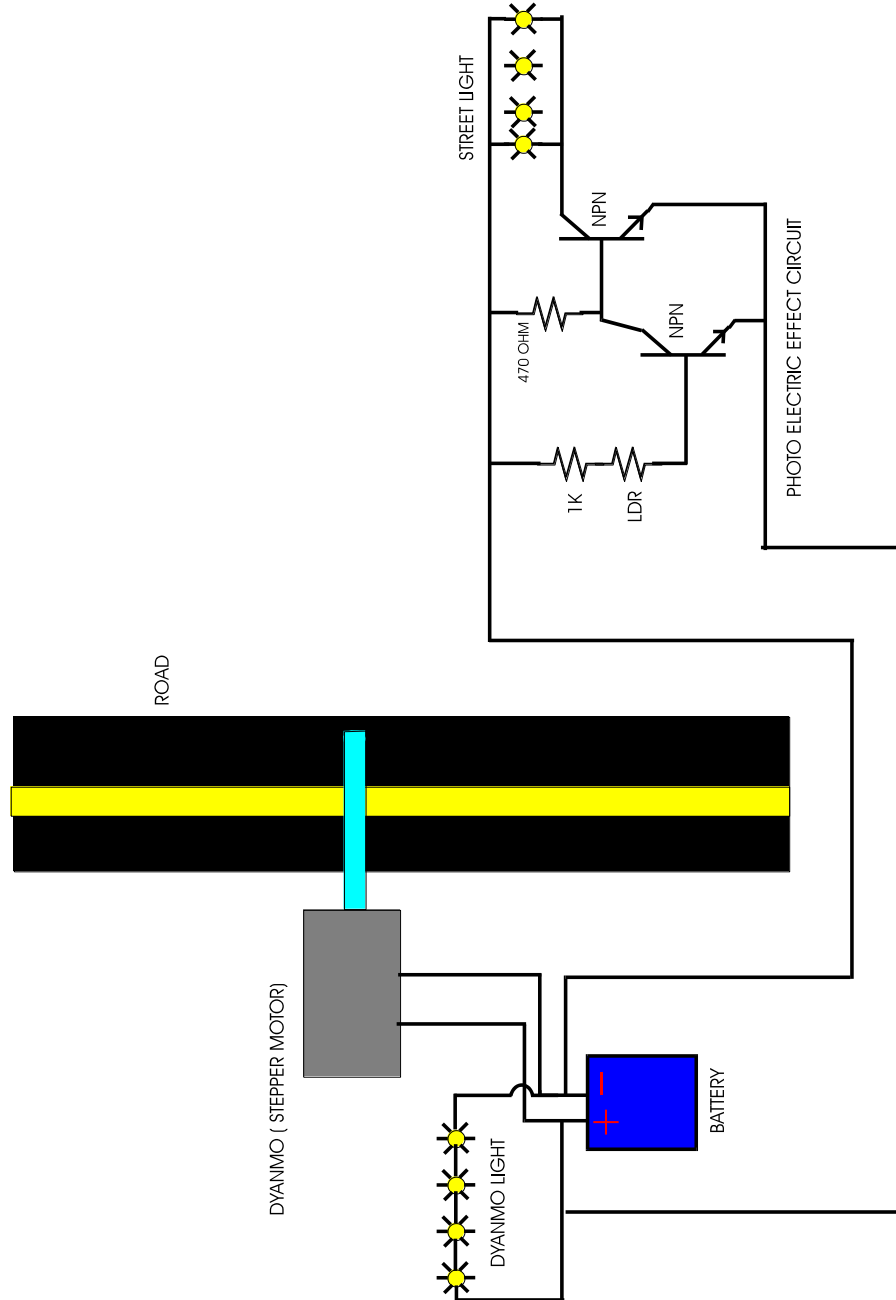

**Fig 2.3**

In this project we show that how we use IC 555 as a automatic street light function. Here in this project IC 555 work as a monostable

**CREATED BY:**

timer. Pin no 4 and 8 of the IC is connected to the positive supply. Pin no 1 of the IC is connected to the ground pin. Pin no 3 is the output pin. On this pin we connect a output L.E.D. LDR is connected to the pin no 2 of the IC via 100 k ohm resistor. When light fall on the LDR then LDR offers a low resistance. When LDR is in dark then LDR offers a high resistance. When we convert the LDR by hand then LDR resistance become high and so pin no 2 become more negative. When pin no 2 become negative then IC 555 triggers itself and output is on. This is the function of the monostable timer.

### **2.3 MATERIAL REQUIRED:**

After the general layout of the speed breaker system has been made of successful working it is necessary to select proper material for the system of refrigeration. This involves the consideration of many facts about available material such as dynamo weight, size shape of the component material cost, fabrication cost, overhead charges and many other properties peculiar to the use of which to member is to be fitted.

The following four types of principle properties of material effect their selection.

1. Mechanical
2. Physical
3. Chemical
4. Form manufacturing point of view.

It is important that the material to be used in such a way as to take full advantage of their natural characteristics following material is selected for the fabrication of speed breaker by road. The roller

**CREATED BY:**  
**ER. GAURAV DWIVEDI**  
**MECHANICAL ENGINEERING**

which is extensively used in speed breaker to generate a electricity are made from a materials like synthetic rubber, rumble strips etc for a low weight vehicles and medium weight vehicles like bikes, scooters, bicycles, auto rickshaw, cabs etc.

## CHAPTER-3

### CONSTRUCTION DETAILS

Power generation using speed breaker and efficient use of energy has been constructed from different components, some of the important components details are given below:

#### **3.1 DYANAMO:**

The dynamo uses rotating coils of wire and magnetic fields to convert mechanical rotation into a pulsing direct electric current through Faraday's law. A dynamo machine consists of a stationary structure, called the stator, which provides a constant magnetic field, and a set of rotating windings called the armature which turn within that field. On small machines the constant magnetic field may be provided by one or more permanent magnets; larger machines have the constant magnetic field provided by one or more electromagnets, which are usually called field current.

The commutator was needed to produce direct current. When a loop of wire rotates in a magnetic field, the potential induced in it reverses with each half turn, generating an alternating current. However, in the early days of electric experimentation, alternating current generally had no known use. The few uses for electricity, such as electroplating, used direct current provided by messy liquid batteries. Dynamos were invented as a replacement for batteries. The commutator is a set of contacts mounted on the machine's shaft, which reverses the connection of the windings to the

**CREATED BY:**  
**ER. GAURAV DWIVEDI**  
**MECHANICAL ENGINEERING**

external circuit when the potential reverses, so instead of alternating current, a pulsing direct current is produced.

### **3.2 FARADAY PRINCIPLE:**



**Fig 3.1** Portable generator side view showing gasoline engine.

In 1831-1832 Michael Faraday discovered that a potential difference is generated between the ends of an electrical conductor that moves perpendicular to a magnetic field. He also built the first electromagnetic generator called the 'Faraday disc', a type of homopolar generator, using a copper disc rotating between the poles of a horseshoe magnet. It produced a small DC voltage, and large amounts of current. The first dynamo based on Faraday's principles was built in 1832 by Hippolyte Pixii, a French instrument maker. It used a permanent magnet which was rotated by a crank. The spinning magnet was positioned so that its north and south poles passed by a piece of iron wrapped with wire. Pixii found that the spinning magnet produced a pulse of current in the wire each time a pole passed the coil. Furthermore, the north and south poles of the magnet induced currents

**CREATED BY:**  
**ER. GAURAV DWIVEDI**  
**MECHANICAL ENGINEERING**

in opposite directions. By adding a commutator, Pixii was able to convert the alternating current to direct current.

Unlike the Faraday disc, many turns of wire connected in series can be used in the moving windings of a dynamo. This allows the terminal voltage of the machine to be higher than a disc can produce, so that electrical energy can be delivered at a convenient voltage. The relationship between mechanical rotation and electric current in a dynamo is reversible; the principles of the electric motor were discovered when it was found that one dynamo could cause a second interconnected dynamo to rotate if current was fed through it.

### **3.3 JEDLIK'S DYNAMO:**

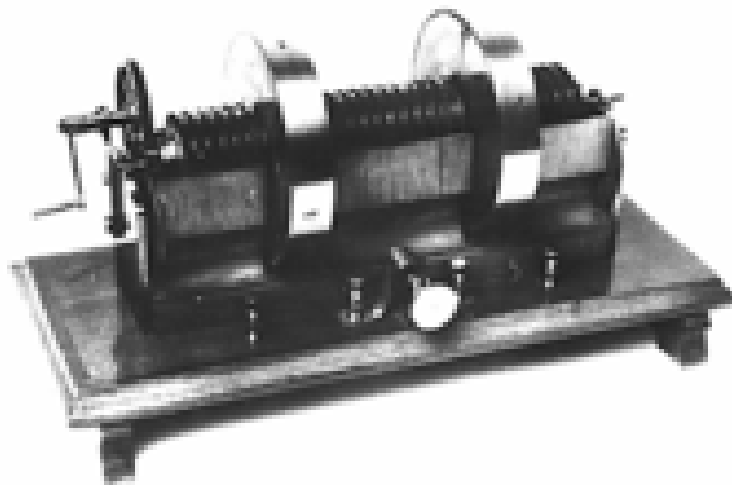

**Fig 3.2** Jedlik's dynamo

In 1827, Anyos Jedlik started experimenting with electromagnetic rotating devices which he called electromagnetic self-rotors. In the prototype of the single-pole electric starter (finished between 1852 and 1854) both the

**CREATED BY:**  
**ER. GAURAV DWIVEDI**  
**MECHANICAL ENGINEERING**

stationary and the revolving parts were electromagnetic. He formulated the concept of the dynamo at least 6 years before Siemens and Wheatstone. In essence the concept is that instead of permanent magnets, two electromagnets opposite to each other induce the magnetic field around the rotor.

### **3.4 GRAMME DYNAMO:**

Both of these designs suffered from a similar problem: they induced "spikes" of current followed by none at all. Antonio Pacinotti, an Italian scientist, fixed this by replacing the spinning coil with a toroidal one, which he created by wrapping an iron ring. This meant that some part of the coil was continually passing by the magnets, smoothing out the current. Zénobe Gramme reinvented this design a few years later when designing the first commercial power plants, which operated in Paris in the 1870s. His design is now known as the Gramme dynamo. Various versions and improvements have been made since then, but the basic concept of a spinning endless loop of wire remains at the heart of all modern dynamos.

The generator moves an electric current, but does not create electric charge, which is already present in the conductive wire of its windings. It is somewhat analogous to a water pump, which creates a flow of water but does not create the water itself.

Other types of electrical generator exist, based on other electrical phenomena such as piezoelectricity, and magneto hydro-dynamics. The construction of a dynamo is similar to that of an electric motor, and all common types of dynamos could work as motors.

**CREATED BY:**  
**ER. GAURAV DWIVEDI**  
**MECHANICAL ENGINEERING**



### **3.5 TERMINOLOGY:**

The parts of a dynamo or related equipment can be expressed in either mechanical terms or electrical terms. Although distinctly separate, these two sets of terminology are frequently used interchangeably or in combinations that include one mechanical term and one electrical term. This causes great confusion when working with compound machines such as a brushless alternator or when conversing with people who are used to working on a machine that is configured differently than the machines that the speaker is used to.

- Mechanical
- Rotor: The rotating part of an alternator, generator, dynamo or motor.
- Stator: The stationary part of an alternator, generator, dynamo or motor.
- Electrical
- Armature: The power-producing component of an alternator, generator, dynamo or motor. The armature can be on either the rotor or the stator.
- Field: The magnetic field component of an alternator, generator, dynamo or motor. The field can be on either the rotor or the stator and can be either an electromagnet or a permanent magnet.

### **3.6 EQUIVALENT CIRCUIT:**

**CREATED BY:**  
**ER. GAURAV DWIVEDI**  
**MECHANICAL ENGINEERING**

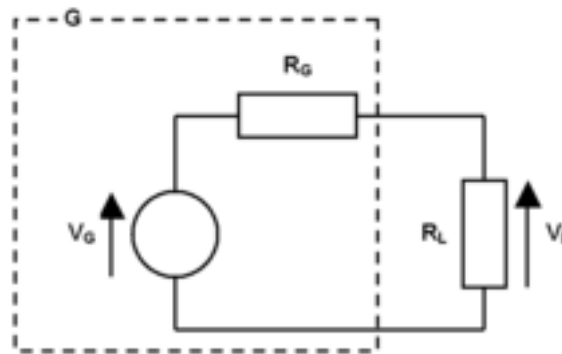

**Fig 3.3** Equivalent circuit of generator and load

$G$  = generator

$V_G$  = generator open-circuit voltage

$R_G$  = generator internal resistance

$V_L$  = generator on-load voltage

$R_L$  = load resistance

- Before starting the generator, measure the resistance across its terminals using an ohmmeter. This is its DC internal resistance  $R_{GDC}$ .
- Start the generator. Before connecting the load  $R_L$ , measure the voltage across the generator's terminals. This is the open-circuit voltage  $V_G$ .
- Connect the load as shown in the diagram, and measure the voltage across it with the generator running. This is the on-load voltage  $V_L$ .
- Measure the load resistance  $R_L$ , if you don't already know it.

### **3.7 MAXIMUM POWER:**

The maximum power theorem applies to generators as it does to any source of electrical energy. This theorem states that the maximum power can be obtained from the generator by making the resistance of the load equal to

**CREATED BY:**  
**ER. GAURAV DWIVEDI**  
**MECHANICAL ENGINEERING**

that of the generator. However, under this condition the power transfer efficiency is only 50%, which means that half the power generated is wasted as heat and Lorentz force or back emf inside the generator. For this reason, practical generators are not usually designed to operate at maximum power output, but at a lower power output where efficiency is greater.

### **3.8 ROLLER:**

Suited for where heavy loads must be moved in confined spaces without loss of precision or rigidity, Tschudin and Heid linear roller cages and guides allows displacement of moving parts in axial direction via use of parallel shafts and sleeves; no radial movement is possible. Rollers offer line contact with guide, enabling low pre-load at assembly to be maintained. Rollers are arranged within plastic or metallic cage in spiral fashion, spread over entire surface area of shaft and sleeve.

Tschudin & Heid linear roller cages and guides are components for machine, instrument, tool and fixture applications. The novel design of the rollers and cages allows the displacement of moving parts in an axial direction through the use of parallel shafts and sleeves. No radial movement is possible. This novel construction is particularly appropriate in cases where heavy loads must be moved in confined spaces without loss of precision or rigidity. The use of special "rollers" instead of balls results in line contact with the guide rather than point contact as with ball-type guides. Because of this line contact, pre-load at assembly can be kept low, which produces a low surface pressure between the rollers and guides. In spite of this, the bearing is rigid, accurate and can be heavily

**CREATED BY:**  
**ER. GAURAV DWIVEDI**  
**MECHANICAL ENGINEERING**

loaded. The rollers are arranged within a plastic or metallic cage in spiral fashion, spread over the entire surface area of the shaft and sleeve, leading to a longer service life of the guide unit.

This is also a low maintenance unit, requiring only a thin lubricating film for normal operation. Complete cylinder linear guides, comprising shaft and sleeve with matched roller cage can be supplied ready for fitting to customer's specifications.

Advanced Machine & Engineering Co., is a manufacturer located in Rockford, Ill., serving the Machine Tool Industry with precision components and accessories, including spindle interface components, work holding devices, and, through our sister company, Hennig, machine enclosures, chip removal and filtration systems. The Fluid Power - Safety markets are served with cylinder rod locks and safety catcher devices; and the Production Saw market with our Am Saw carbide saw machines and Speed cut blade products. AME has manufacturing partners and customers around the world.

**CREATED BY:**  
**ER. GAURAV DWIVEDI**  
**MECHANICAL ENGINEERING**



**Fig 3.4** Roller

Henning, Inc. designs and produces custom machine protection and chip/coolant management products for state-of-the-art machine tools. Henning products are designed to protect against corrosion, debris and common workplace contaminants. Manufacturing facilities are located in the U.S., Germany, Brazil, India, Japan, China and South Korea. Repair centers are located in Machesney Park, IL; Chandler, OK; Livonia, MI; Blue Ash, OH; Mexico City, Mexico; and Saltillo, Mexico.

### **3.9 MICROCONTROLLER:**

A **microcontroller** is a small computer on a single integrated circuit containing a processor core, memory, and programmable input/output peripherals. Program memory in the form

**CREATED BY:**  
**ER. GAURAV DWIVEDI**  
**MECHANICAL ENGINEERING**

of NOR flash or OTP ROM is also often included on chip, as well as a typically small amount of RAM. Microcontrollers are designed for embedded applications, in contrast to the microprocessors used in personal computers or other general purpose applications.

Microcontrollers are used in automatically controlled products and devices, such as automobile engine control systems, implantable medical devices, remote controls, office machines, appliances, power tools, and toys. By reducing the size and cost compared to a design that uses a separate microprocessor, memory, and input/output devices, microcontrollers make it economical to digitally control even more devices and processes. Mixed signal microcontrollers are common, integrating analog components needed to control non-digital electronic systems. Some microcontrollers may use four-bit words and operate at clock rate frequencies as low as 4 kHz, for low power consumption (mill watts or microwatts). They will generally have the ability to retain functionality while waiting for an event such as a button press or other interrupt; power consumption while sleeping (CPU clock and most peripherals off) may be just nanowatts, making many of them well suited for long lasting battery applications. Other microcontrollers may serve performance-critical roles, where they may need to act more like a digital signal processor (DSP). Microcontrollers were originally programmed only in assembly language, but various high-level programming languages are now also in common use to target microcontrollers.

**CREATED BY:**  
**ER. GAURAV DWIVEDI**  
**MECHANICAL ENGINEERING**

These languages are either designed especially for the purpose, or versions of general purpose languages such as the C programming language. Compilers for general purpose languages will typically have some restrictions as well as enhancements to better support the unique characteristics of microcontrollers. Some microcontrollers have environments to aid developing certain types of applications. Microcontroller vendors often make tools freely available to make it easier to adopt their hardwareher clock speeds and power consumption.



**Fig 3.5** Microcontroller

**CREATED BY:**  
**ER. GAURAV DWIVEDI**  
**MECHANICAL ENGINEERING**

Many microcontrollers are so quirky that they effectively require their own non-standard dialects of C, such as SDCC for the 8051, which prevent using standard tools (such as code libraries or static analysis tools) even for code unrelated to hardware features. Interpreters are often used to hide such low level quirks. Interpreter firmware is also available for some microcontrollers. For example, BASIC on the early microcontrollers Intel 8052; BASIC and FORTH on the Zilog Z8 as well as some modern devices. Typically these interpreters support interactive programming.

Simulators are available for some microcontrollers, such as in Microchip's MPLAB environment. These allow a developer to analyze what the behavior of the microcontroller and their program should be if they were using the actual part. A simulator will show the internal processor state and also that of the outputs, as well as allowing input signals to be generated. While on the one hand most simulators will be limited from being unable to simulate much other hardware in a system, they can exercise conditions that may otherwise be hard to reproduce at will in the physical implementation, and can be the quickest way to debug and analyze problems.

Recent microcontrollers are often integrated with on-chip debug circuitry that when accessed by an in-circuit emulator via JTAG, allow debugging of the firmware with a debugger.

**CREATED BY:**  
**ER. GAURAV DWIVEDI**  
**MECHANICAL ENGINEERING**



### **3.10 PHOTODIODE:**

A **photodiode** is a type of photo detector capable of converting light into either current or voltage, depending upon the mode of operation. Photodiodes are similar to regular semiconductor diodes except that they may be either exposed (to detect vacuum UV or X-rays) or packaged with a window or optical fiber connection to allow light to reach the sensitive part of the device. Many diodes designed for use specifically as a photodiode will also use a PIN junction rather than the typical PN junction.

A photodiode is a PN junction or PIN structure. When a photon of sufficient energy strikes the diode, it excites an electron, thereby creating a mobile electron and a positively charged electron hole. If the absorption occurs in the junction's depletion region, or one diffusion length away from it, these carriers are swept from the junction by the built-in field of the depletion region. Thus holes move toward the anode, and electrons toward the cathode, and a photocurrent is produced.

When used in zero bias or photovoltaic mode, the flow of photocurrent out of the device is restricted and a voltage builds up. The diode becomes forward biased and "dark current" begins to flow across the junction in the direction opposite to the photocurrent. This mode is responsible for the photovoltaic effect, which is the basis for solar cells—in fact, a solar cell is just a large area photodiode.

**CREATED BY:**  
**ER. GAURAV DWIVEDI**  
**MECHANICAL ENGINEERING**

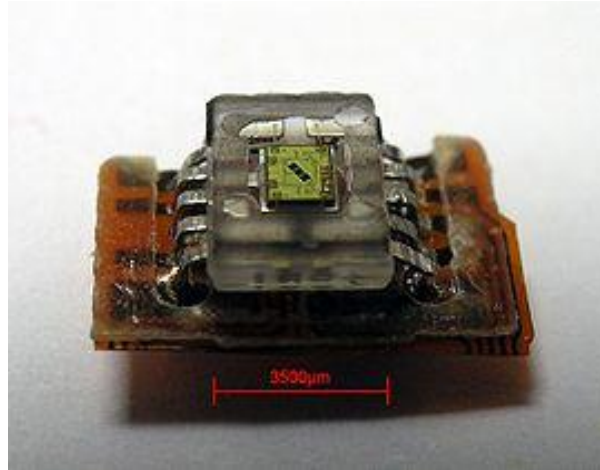

**Fig 3.6** Photodiode

In this mode the diode is often reverse biased, dramatically reducing the response time at the expense of increased noise. This increases the width of the depletion layer, which decreases the junction's capacitance resulting in faster response times. The reverse bias induces only a small amount of current (known as saturation or back current) along its direction while the photocurrent remains virtually the same. The photocurrent is linearly proportional to the luminance.

Although this mode is faster, the photoconductive mode tends to exhibit more electronic noise. The leakage current of a good PIN diode is so low ( $< 1\text{nA}$ ) that the Johnson–Nyquist noise of the load resistance in a typical circuit often dominates.

### **3.11 LED:**

**CREATED BY:**  
**ER. GAURAV DWIVEDI**  
**MECHANICAL ENGINEERING**

A **light-emitting diode (LED)** is a semiconductor device that emits incoherent narrow-spectrum light when electrically biased in the forward direction of the P-n junction. This effect is a form of electroluminescence. LEDs are small extended sources with extra optics added to the chip, which emit a complex intensity spatial distribution. The color of the emitted light depends on the composition and condition of the semi conducting material used, and can be infrared, visible or near-ultraviolet.



**Fig 3.7** Light emitting diode

The kinetic energy of the wheel gets converted in to electrical energy by the help of generator. This electrical energy is shown by LED.

### **3.12 IC 555 TIMER:**

IC555 timer available in 8 pin DIP or To-99 Package is one of the most popular and versatile sequential logic devices which can be used in monostable and a stable mode its inputs and outputs are directly compatible both  $TT_1$  and CMOS logic circuit. The functional diagram of 555 timer is shown in fig. On a negative going excursion of the trigger input when the

**CREATED BY:**

**ER. GAURAV DWIVEDI  
MECHANICAL ENGINEERING**

trigger input passes through the reference voltage  $V_{CC}/3$ , the output of the comparator 2 goes high and sets the flip-flop ( $\phi=1$ ). On a resistive going excursion of the threshold input, the output of a comparator 1 goes high when the threshold voltage passes through the reference voltage  $2V_{CC}/3$ . This reset the flip-flop ( $\phi = 1$ ). The flip flop is cleared when the reset input is less than about 0.4V. When this input is not required to be used it is normally return to  $V_{CC}$ .

An extend timing capacitor  $C$  is to be connected between the discharge terminal and ground. When the flip flop is in the reset state, its  $\phi = 1$ . This drives  $T1$  to situation thereby discharging the timing capacitor. The timing cycles starts when the flip flop goes to set state and therefore  $T_1$  is off. The timing capacitor charges with the time constant  $T=R_A C$ . Where  $C$  is the timing capacitor and  $R_A$  is an external resistor to be connected between the discharge terminal and  $V_{CC}$ .

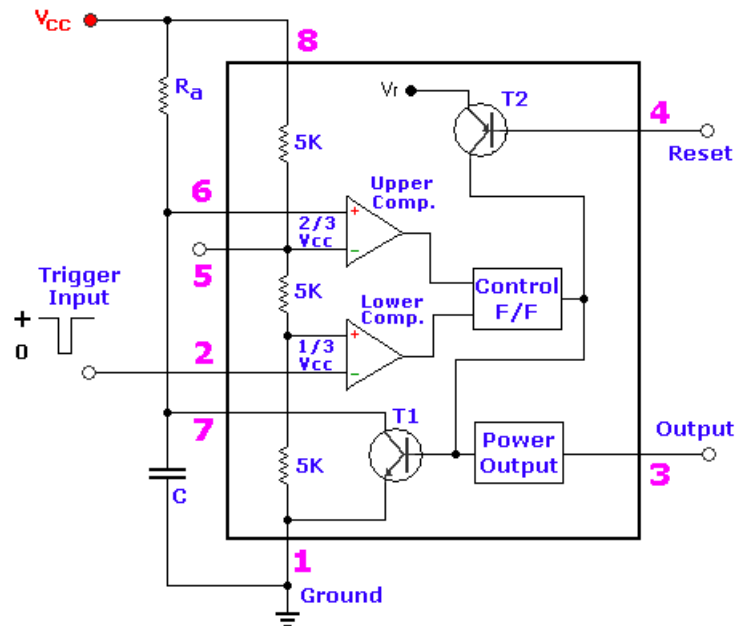

**Fig 3.8.1** NE555 Timer Block Diagram

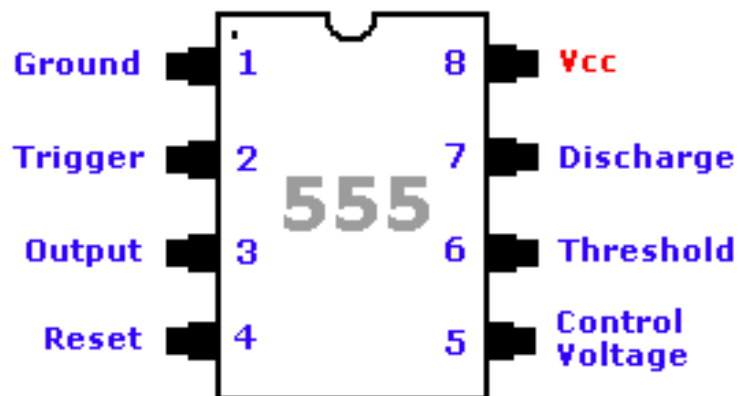

**Fig 3.8.2** NE555 Timer Pin Description

The output is at logic 1 whenever the transistor T<sub>1</sub> is off and at logic 0 T<sub>1</sub> is on. The load can be connected either between the output terminal and V<sub>cc</sub> or between the output and ground terminals. The voltage

**CREATED BY:**  
**ER. GAURAV DWIVEDI**  
**MECHANICAL ENGINEERING**

corresponding to high output is approximately 0-5V below  $V_{cc}$  and for low is approximately 0.1V.

### **3.13 MONOSTABLE MULTIVIBRATER USING 555 TIMER:**

A monostable multivibrator circuit using a 555 timer is shown in fig. If the trigger input is held high, then under steady – state condition the transistor  $T_1$  is on the discharge and output terminal are at low level it can be verified that  $T_1$  can not be off under steady state condition. When negative pulse applied at trigger input across the voltage  $V_{cc}/3$  the output of comparator 2 goes high which sets the flip flop and consequently.  $T_1$  turn off and output goes high. The capacitor C starts getting charged to  $V_{cc}$  with timer constant ( $T = R_A.C$ ).

### **3.14 DEFINITION OF PIN FUNCTION:**

**Pin 1 (Ground):** The ground (or common) pin is the most-negative supply potential of the device, which is normally connected to circuit common (ground) when operated from positive supply voltages.

**Pin 2 (Trigger):** This pin is the input to the lower comparator and is used to set the latch, which in turn causes the output to go high. This is the beginning of the timing sequence in monostable operation. Triggering is accomplished by taking the pin from above to below a voltage level of  $1/3 V_+$  (or, in general, one-half the voltage appearing at pin 5). The action of the trigger input is level-sensitive, allowing slow rate-of-change waveforms,

**CREATED BY:**

**ER. GAURAV DWIVEDI  
MECHANICAL ENGINEERING**

as well as pulses, to be used as trigger sources. The trigger pulse must be of shorter duration than the time interval determined by the external R and C. If this pin is held low longer than that, the output will remain high until the trigger input is driven high again. One precaution that should be observed with the trigger input signal is that it must not remain lower than  $1/3 V+$  for a period of time longer than the timing cycle. If this is allowed to happen, the timer will re-trigger itself upon termination of the first output pulse. Thus, when the timer is driven in the monostable mode with input pulses longer than the desired output pulse width, the input trigger should effectively be shortened by differentiation. The minimum-allowable pulse width for triggering is somewhat dependent upon pulse level, but in general if it is greater than the  $1\mu\text{S}$  (micro-Second), triggering will be reliable. A second precaution with respect to the trigger input concerns storage time in the lower comparator. This portion of the circuit can exhibit normal turn-off delays of several microseconds after triggering; that is, the latch can still have a trigger input for this period of time after the trigger pulse. In practice, this means the minimum monostable output pulse width should be in the order of  $10\mu\text{S}$  to prevent possible double triggering due to this effect. The voltage range that can safely be applied to the trigger pin is between  $V+$  and ground. A dc current, termed the trigger current, must also flow from this terminal into the external circuit. This current is typically  $500\text{nA}$  (nano-amp) and will define the upper limit of resistance allowable from pin 2 to ground. For an actable configuration operating at  $V+ = 5$  volts, this resistance is  $3$  Mega-ohm; it can be greater for higher  $V+$  levels.

**CREATED BY:**  
**ER. GAURAV DWIVEDI**  
**MECHANICAL ENGINEERING**

**Pin 3 (Output):** The output of the 555 comes from a high-current totem-pole stage made up of transistors Q20 - Q24. Transistors Q21 and Q22 provide drive for source-type loads, and their Darlington connection provides a high-state output voltage about 1.7 volts less than the  $V^+$  supply level used. Transistor Q24 provides current-sinking capability for low-state loads referred to  $V^+$  (such as typical TTL inputs). Transistor Q24 has a low saturation voltage, which allows it to interface directly, with good noise margin, when driving current-sinking logic. Exact output saturation levels vary markedly with supply voltage, however, for both high and low states. At a  $V^+$  of 5 volts, for instance, the low state  $V_{ce(sat)}$  is typically 0.25 volts at 5 mA. Operating at 15 volts, however, it can sink 200mA if an output-low voltage level of 2 volts is allowable (power dissipation should be considered in such a case, of course). High-state level is typically 3.3 volts at  $V^+ = 5$  volts; 13.3 volts at  $V^+ = 15$  volts. Both the rise and fall times of the output waveform are quite fast, typical switching times being 100nS. The state of the output pin will always reflect the inverse of the logic state of the latch, and this fact may be seen by examining Fig 3.8. Since the latch itself is not directly accessible, this relationship may be best explained in terms of latch-input trigger conditions. To trigger the output to a high condition, the trigger input is momentarily taken from a higher to a lower level. [See "Pin 2 - Trigger"]. This causes the latch to be set and the output to go high. Actuation of the lower comparator is the only manner in which the output can be placed in the high state. The output can be returned to a low state by causing the threshold to go from a lower to a higher level [see

**CREATED BY:**

**ER. GAURAV DWIVEDI**

**MECHANICAL ENGINEERING**



"Pin 6 - Threshold"], which resets the latch. The output can also be made to go low by taking the reset to a low state near ground [see "Pin 4 - Reset"]. The output voltage available at this pin is approximately equal to the  $V_{cc}$  applied to pin 8 minus 1.7V.

**Pin 4 (Reset):** This pin is also used to reset the latch and return the output to a low state. The reset voltage threshold level is 0.7 volt, and a sink current of 0.1mA from this pin is required to reset the device. These levels are relatively independent of operating  $V_{+}$  level; thus the reset input is TTL compatible for any supply voltage. The reset input is an overriding function; that is, it will force the output to a low state regardless of the state of either of the other inputs. It may thus be used to terminate an output pulse prematurely, to gate oscillations from "on" to "off", etc. Delay time from reset to output is typically on the order of 0.5  $\mu$ S, and the minimum reset pulse width is 0.5  $\mu$ S. Neither of these figures is guaranteed, however, and may vary from one manufacturer to another. In short, the reset pin is used to reset the flip-flop that controls the state of output pin 3. The pin is activated when a voltage level anywhere between 0 and 0.4 volt is applied to the pin. The reset pin will force the output to go low no matter what state the other inputs to the flip-flop are in. When not used, it is recommended that the reset input be tied to  $V_{+}$  to avoid any possibility of false resetting.

**Pin 5 (Control Voltage):** This pin allows direct access to the  $2/3 V_{+}$  voltage-divider point, the reference level for the upper comparator. It also allows indirect access to the lower comparator, as there is a 2:1 divider (R8

**CREATED BY:**

**ER. GAURAV DWIVEDI**

**MECHANICAL ENGINEERING**

- R9) from this point to the lower-comparator reference input, Q13. Use of this terminal is the option of the user, but it does allow extreme flexibility by permitting modification of the timing period, resetting of the comparator, etc. When the 555 timer is used in a voltage-controlled mode, its voltage-controlled operation ranges from about 1 volt less than  $V^+$  down to within 2 volts of ground (although this is not guaranteed). Voltages can be safely applied outside these limits, but they should be confined within the limits of  $V^+$  and ground for reliability. By applying a voltage to this pin, it is possible to vary the timing of the device independently of the RC network. The control voltage may be varied from 45 to 90% of the  $V_{cc}$  in the monostable mode, making it possible to control the width of the output pulse independently of RC. When it is used in the astable mode, the control voltage can be varied from 1.7V to the full  $V_{cc}$ . Varying the voltage in the astable mode will produce a frequency modulated (FM) output. In the event the control-voltage pin is not used, it is recommended that it be bypassed, to ground, with a capacitor of about 0.01 $\mu$ F (10nF) for immunity to noise, since it is a comparator input. This fact is not obvious in many 555 circuits since I have seen many circuits with 'no-pin-5' connected to anything, but this is the proper procedure. The small ceramic cap may eliminate false triggering.

**Pin 6 (Threshold):** Pin 6 is one input to the upper comparator (the other being pin 5) and is used to reset the latch, which causes the output to go low. Resetting via this terminal is accomplished by taking the terminal from below to above a voltage level of  $2/3 V^+$  (the normal voltage on pin 5). The

**CREATED BY:**

**ER. GAURAV DWIVEDI  
MECHANICAL ENGINEERING**

action of the threshold pin is level sensitive, allowing slow rate-of-change waveforms. The voltage range that can safely be applied to the threshold pin is between  $V^+$  and ground. A dc current, termed the threshold current, must also flow into this terminal from the external circuit. This current is typically  $0.1\mu\text{A}$ , and will define the upper limit of total resistance allowable from pin 6 to  $V^+$ . For either timing configuration operating at  $V^+ = 5$  volts, this resistance is 16 Mega-ohm. For 15 volt operation, the maximum value of resistance is 20 MegaOhms.

**Pin 7 (Discharge):** This pin is connected to the open collector of a npn transistor (Q14), the emitter of which goes to ground, so that when the transistor is turned "on", pin 7 is effectively shorted to ground. Usually the timing capacitor is connected between pin 7 and ground and is discharged when the transistor turns "on". The conduction state of this transistor is identical in timing to that of the output stage. It is "on" (low resistance to ground) when the output is low and "off" (high resistance to ground) when the output is high. In both the monostable and astable time modes, this transistor switch is used to clamp the appropriate nodes of the timing network to ground. Saturation voltage is typically below 100mV (milli-Volt) for currents of 5 mA or less, and off-state leakage is about 20nA (these parameters are not specified by all manufacturers, however). Maximum collector current is internally limited by design, thereby removing restrictions on capacitor size due to peak pulse-current discharge. In certain applications, this open collector output can be used as an

**CREATED BY:**  
**ER. GAURAV DWIVEDI**  
**MECHANICAL ENGINEERING**

auxiliary output terminal, with current-sinking capability similar to the output (pin 3).

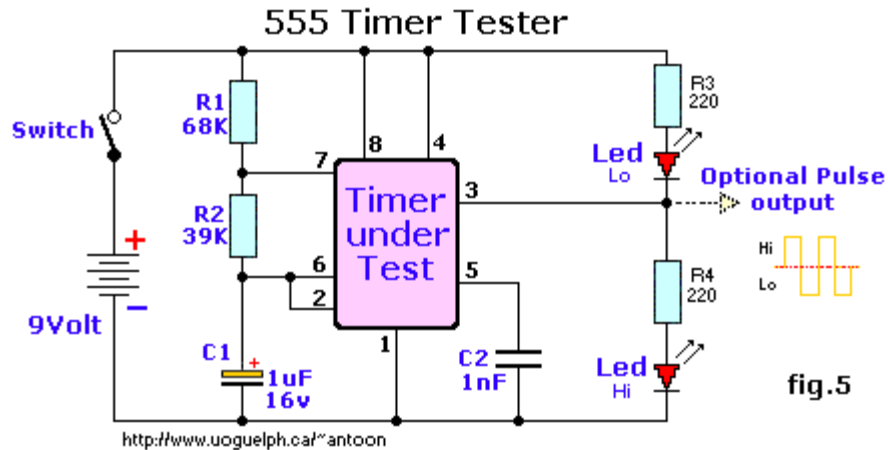

**Fig 3.9**

**Pin 8 (V +):** The V+ pin (also referred to as Vcc) is the positive supply voltage terminal of the 555 timer IC. Supply-voltage operating range for the 555 is +4.5 volts (minimum) to +16 volts (maximum), and it is specified for operation between +5 volts and + 15 volts. The device will operate essentially the same over this range of voltages without change in timing period. Actually, the most significant operational difference is the output drive capability, which increases for both current and voltage range as the supply voltage is increased. Sensitivity of time interval to supply voltage change is low, typically 0.1% per volt. There are special and military devices available that operate at voltages as high as 18 V.

Try the simple 555 testing-circuit of Fig. 5. to get you going, and test all your 555 timer IC's. I build several for friends and family. I bring my own tester to ham-fests and what not to instantly do a

**CREATED BY:**  
**ER. GAURAV DWIVEDI**  
**MECHANICAL ENGINEERING**

check and see if they are oscillating. Or use as a trouble shooter in 555 based circuits. This tester will quickly tell you if the timer is functional or not. Although not foolproof, it will tell if the 555 is shorted or oscillating. If both Led's are flashing the timer is most likely in good working order. If one or both Led's are either off or on solid the timer is defective.

### **3.15 TRANSISTOR:**

A transistor is semi conductor device consisting of three regions separated by two P-N junctions. The three regions are Base, Emitter & Collector.

The base may be of N- type or P- type. The emitter and collector have same impurities but different from that of base. Thus if base is of N- type then emitter and collector are of P- type then transistor is called P-N-P transistor and vice versa transistor is called N-P-N transistor.

The base is made thin and number density of majority carriers is always less than emitter and collector. The base provides junction for proper interaction between emitter and collector.

Electrons are majority charge carriers in N- region and in P-region, holes are the majority charge carriers. Thus two types of charge carriers are involved in current flow through N-P-N or P-N-P transistor.

### **3.16 SYMBOLS FOR TRANSISTORS:**

In schematic symbols, the emitter is always represented by an arrow indicating the direction of conventional current in the device. In case of N-P-N transistor arrow points away from base and in case of P-N-P transistor it points towards base.

When transistor is used in circuit, emitter - base junction is always forward biased while base - collector junction is always reverse biased.

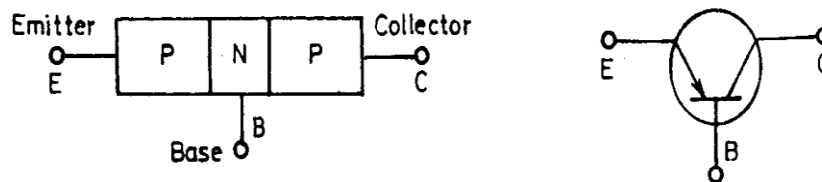
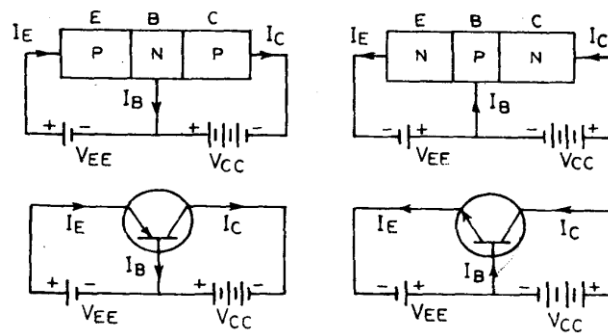

**Fig 3.10** Structure and Symbol of P-N-P Transistor

### 3.17 BIASING OF TRANSISTOR:

The two junctions can be biased in four different ways:

- Both junctions may be forward biased. It causes large current to flow across junctions. Transistor is to be operated in “SATURATION REGION”.
- Both junctions may be reversed biased. It causes very small current to flow across junctions. Transistor is to be operated in “CUT OFF REGION”.
- E-B junction is forward biased and C-B junction is reverse biased. The transistor is said to be operated in “ACTIVE REGION”. Most of the transistors work in this region.
- E-B junction is reversed biased and C-B junction is forward biased. The transistor is said to be operated in “INVERTED MODE”.



**Fig 3.11**

P-N-P Transistor Biasing (b) N-P-N Transistor Biasing

### 3.18 CIRCUIT CONFIGURATIONS:

There are three possible ways in which a transistor can be connected in the circuit which are following:

- Common Base Configuration: Base is made common in this configuration.
- Common Emitter Configuration: Emitter is made common in this configuration.
- Common Collector Configuration: Collector is made common in this configuration.

### 3.19 DIODE:

It is a P-type region and N-type region formed in the same crystal structure, and hence a P-N junction is produced. Some of the conduction electrons near the junction diffuse in to P-type semiconductor from the N-type semiconductor across the junction combining with the holes. The loss of electrons makes the N-type semiconductor positively charged and hence the neutralization of the holes on the other hand makes P-type semiconductor

**CREATED BY:**  
**ER. GAURAV DWIVEDI**  
**MECHANICAL ENGINEERING**

negatively charged. This region where positive and negative charges develop is called depletion region.

If a P-region is made positive with respect to the N-region by an external circuit then junction is forward biased and junction has a very low resistance to the flow of current. Holes in the positive P-type material are attracted across the junction to the negative side and the free electrons in the N-type material are like wise attracted to the opposite side. If a positive voltage is applied to N-zone with respect to the P-zone terminal, the P-N junction is reverse biased.

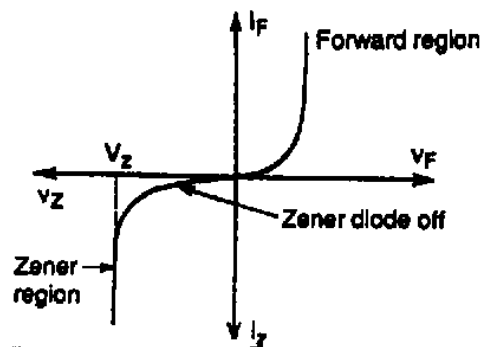

**Fig 3.12**

Volt-Ampere Characteristics of a P-N Diode

### **3.20 TEMPRATURE DEPENDENCE OF V-I CHARACTERISTIC:**

The cut-in voltage decreases at the rate of 2.5 mV/°C. Also above 25°C, the reverse saturation current  $I_0$  doubles for every 6°C (10°C) for Si (Ge) diodes. However, the shape of overall characteristic does not alter with temperature.

### **3.21 RESISTANCE:**

**CREATED BY:**

**ER. GAURAV DWIVEDI**

**MECHANICAL ENGINEERING**



Resistance is the electronic component used to control the current passing through the circuit. They are calibrated in ohms. In the other words resistance are circuit elements having the function introducing electrical resistance into the circuit. There are three basic types:

1. Fixed Resistance
2. Rheostat
3. Potentiometer

A fixed Resistance is a two terminal resistance whose electrical resistance is constant. A rheostat is a resistance that can be changed in resistance value without opening the circuit to make adjustment.

A potentiometer is an adjustable resistance with three terminals one each end of the resistance element and third movable along

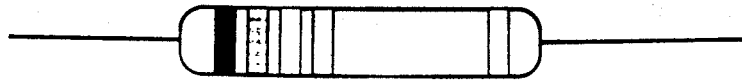

length.

**Fig 3.13** Resistance

### **3.22 CAPACITOR:**

A capacitor is a device capable of storing an electric charge (static electricity). It consists of two metal plates separated by dielectric material. Capacitors are available in values ranging from less than one picofarad to thousands of microfarad. While using a capacitor its ratings must be

**CREATED BY:**  
**ER. GAURAV DWIVEDI**  
**MECHANICAL ENGINEERING**

carefully observed to make certain that the potential to be applied across the capacitor is not greater than the rated value.

### 3.22.1 CERAMIC CAPACITOR:

In this project, 0.01 microfarad capacitor is a ceramic capacitor. The basis of the ceramic material is mainly barium titanate or a similar material, but other ceramic substances including hydrous silicate of magnesia or talc are also used. The electrodes are applied in the form of silver which is either spread or plated on to the opposite faces of a thin tube, wafer or disc made from the ceramic material. Connecting wires are then soldered to this deposit and the whole capacitor dipped in for a suitable coating.

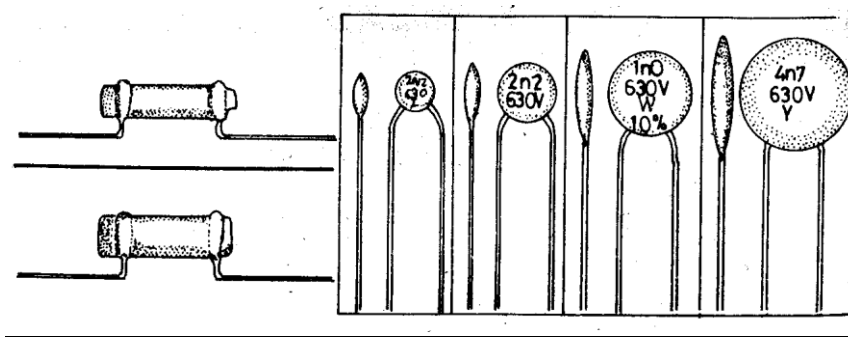

**Fig 3.14** Tabular and Disc Type Ceramic Capacitors

### 3.22.2 ELECTROLYTIC CAPACITOR:

In this project, 10 $\mu$ f capacitor is an electrolytic capacitor. In this type of capacitors, the dielectric consists of an extremely thin film of aluminum oxide formed on one of its aluminum foil plates. Intimate contact with the other plate is achieved by impregnating the paper between the foils with an

**CREATED BY:**  
**ER. GAURAV DWIVEDI**  
**MECHANICAL ENGINEERING**

electrolyte in the form of viscous substance, such as ammonium borate. The sandwich is then rolled into a cylindrical element and housed in either metallic cardboard, plastic or ceramic protective tube.

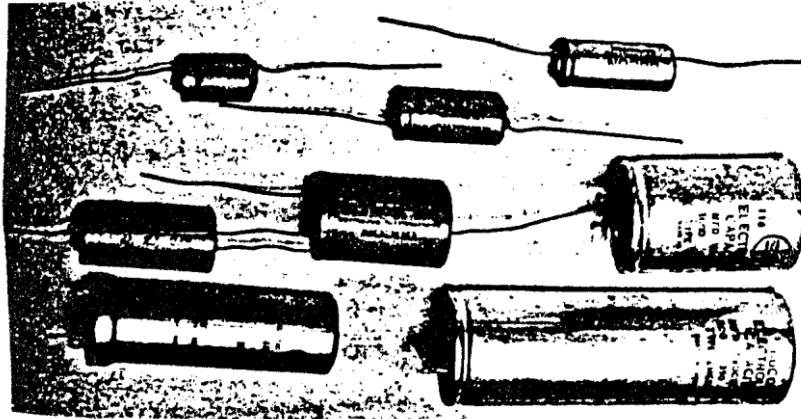

**Fig 3.15** Electrolytic and Tantalum Capacitor

### 3.23 INTEGRATED CIRCUIT:



**Fig 3.16** Integrated circuit

Integrated circuits were made possible by experimental discoveries which showed that semiconductor devices could perform the

functions of vacuum tubes, and by mid-20th-century technology advancements in semiconductor device fabrication. The integration of large numbers of tiny transistors into a small chip was an enormous improvement over the manual assembly of circuits using electronic components. The integrated circuits mass production capability, reliability, and building-block approach to circuit design ensured the rapid adoption of standardized ICs in place of designs using discrete transistors.

There are two main advantages of ICs over discrete circuits: cost and performance. Cost is low because the chips, with all their components, are printed as a unit by photolithography and not constructed as one transistor at a time. Furthermore, much less material is used to construct a circuit as a packaged IC die than as a discrete circuit. Performance is high since the components switch quickly and consume little power (compared to their discrete counterparts) because the components are small and close together. As of 2006, chip areas range from a few square millimeters to around  $350 \text{ mm}^2$ , with up to 1 million transistors per  $\text{mm}^2$ .

**CREATED BY:**

## CHAPTER-4

### FUTURE SCOPE

In a present scenario such kind of speed breaker are being used for a light vehicles in various countries. Now in a future that technology can be used for heavy vehicles, thus increasing input torque to various mechanism and ultimately output of the generator or dynamo. To enhance the efficiency of that system, engineers have to find out more compact, reliable and suitable mechanism to produce electricity.

Future goal of that system to enhance the efficiency, so there should be rapid rotation of the dynamo shaft, to do the same we can employ a flywheel to the system in such a way that it would be increase the rotation per minute of dynamo or a generator. Generally a flywheel used in machines serves as a reservoir which stores energy during the period when supply energy more than the requirement and releases it during the period when the requirement of energy more than the supply. **Flywheel energy storage** (FES) works by accelerating a rotor (flywheel) to a very high speed and maintaining the energy in the system as rotational energy. When energy is extracted from the system, the flywheel's rotational speed is reduced as a consequence of the principle of conservation of energy; adding energy to the system correspondingly results in an increase in the speed of the flywheel i.e. increasing the rotational energy of the shaft. Advanced FES

**CREATED BY:**

**ER. GAURAV DWIVEDI**

**MECHANICAL ENGINEERING**

systems have rotors made of high strength carbon filaments, suspended by magnetic bearings, and spinning at speeds from 20,000 to over 50,000 rpm in a vacuum enclosure.

Stepper motor can be replaced by the dynamo in single way traffic system to produce electricity from speed breakers. Stepper motors operate differently from normal DC motors, which rotate when voltage is applied to their terminals. Stepper motors, on the other hand, effectively have multiple "toothed" electromagnets arranged around a central gear-shaped piece of iron. The electromagnets are energized by an external control circuit. To make the motor shaft turn, first one electromagnet is given power, which makes the gear's teeth magnetically attracted to the electromagnet's teeth. When the gear's teeth are thus aligned to the first electromagnet, they are slightly offset from the next electromagnet. So when the next electromagnet is turned on and the first is turned off, the gear rotates slightly to align with the next one, and from there the process is repeated. Each of those slight rotations is called a "step." In that way, the motor can be turned by a precise angle.

#### **4.1 STEPPER MOTOR:**

Stepper motors are constant-power devices (power = angular velocity x torque). As motor speed increases, torque decreases. The torque curve may be extended by using current limiting drivers and increasing the driving voltage.

Steppers exhibit more vibration than other motor types, as the discrete step tends to snap the rotor from one position to another. This

**CREATED BY:**  
**ER. GAURAV DWIVEDI**  
**MECHANICAL ENGINEERING**

vibration can become very bad at some speeds and can cause the motor to lose torque. The effect can be mitigated by accelerating quickly through the problem speed range, physically damping the system, or using a micro-stepping driver. Motors with a greater number of phases also exhibit smoother operation than those with fewer phases.

## **4.2 OPEN LOOP VERSUS CLOSED LOOP COMMUTATION:**

Steppers are generally commutated open loop, i.e. the driver has no feedback on where the rotor actually is. Stepper motor systems must thus generally be over engineered, especially if the load inertia is high, or there is widely varying load, so that there is no possibility that the motor will lose steps. This has often caused the system designer to consider the trade-offs between a closely sized but expensive servomechanism system and an oversized but relatively cheap stepper.

A new development in stepper control is to incorporate a rotor position feedback, so that the commutation can be made optimal for torque generation according to actual rotor position. This turns the stepper motor into a high pole count brushless servo motor, with exceptional low speed torque and position resolution. An advance on this technique is to normally run the motor in open loop mode, and only enter closed loop mode if the rotor position error becomes too large -- this will allow the system to avoid hunting or oscillating, a common servo problem.

## **4.3 TYPES:**

There are three main types of stepper motors.

**CREATED BY:**  
**ER. GAURAV DWIVEDI**  
**MECHANICAL ENGINEERING**

- Permanent Magnet Stepper
- Hybrid Synchronous Stepper
- Variable Reluctance Stepper

#### **4.4 TWO PHASE STEPPER MOTOR:**

There are two basic winding arrangements for the electromagnetic coils in a two phase stepper motor: bipolar and unipolar.

##### **4.4.1 UNIPOLAR MOTORS:**

A unipolar stepper motor has logically two windings per phase, one for each direction of current. Since in this arrangement a magnetic pole can be reversed without switching the direction of current, the commutation circuit can be made very simple (e.g. a single transistor) for each winding. Typically, given a phase, one end of each winding is made common: giving three leads per phase and six leads for a typical two phase motor. Often, these two phase commons are internally joined, so the motor has only five leads.



## **CHAPTER-5**

### **CONCLUSION**

It is a non-conventional type of producing energy. The existing source of energy such as coal, oil etc may not be adequate to meet the ever increasing energy demands. These conventional sources of energy are also depleting and may be exhausted at the end of the century or beginning of the next century. Consequently sincere and untiring efforts shall have to be made by engineers in exploring the possibilities of harnessing energy from several non-conventional energy sources. This project is a one step towards that way. The overall goal was to design the speed breaker System while keeping the engineering, producer and customer models in check. The reason why this feature was used more than all of the other features are because the other features would not have as much effect on the complete system. By changing the size and desirable price, weight and capacity can be realized.

We used a survey to find out how the price, weight and capacity were scaled. Much was learned on how to and not to conduct a survey. A preliminary survey should have been conducted to determine a realistic value of variables. Also many of choices were not close enough

**CREATED BY:**  
**ER. GAURAV DWIVEDI**  
**MECHANICAL ENGINEERING**

together to get a reasonable cut off value. Therefore the data that was produced using conjoint analysis was most likely not as accurate as it could have been.

Future work would consist of a redesign of this model to see exactly how much data we may be missing with the assumption that we made with low price, weight and capacity. Despite all the assumptions, we still have realized that this product can be very marketable and that the demand is extremely large which means this is a viable design that will yield a high return on an investment.

## REFERENCES

1. Automobile Engineering : Kirpal Singh
2. Automobile Engineering : G.B.S. Narang
3. Automobile Engineering : S.M. Pandey & K.K. Shah
4. Basic Automobile Engineering : C.P. Nakra
5. A Text Book of Machine Design : R.S Khurmi & J.K. Gupta
6. Digital Systems Principles & Applications : Ronald Ltocci.
7. Digital Design : Morris Manu.

**CREATED BY:**